

EXHIBITION COPY

DA-039-2022-2023

SUBMISSIONS CLOSE 4PM 6 APRIL 2023

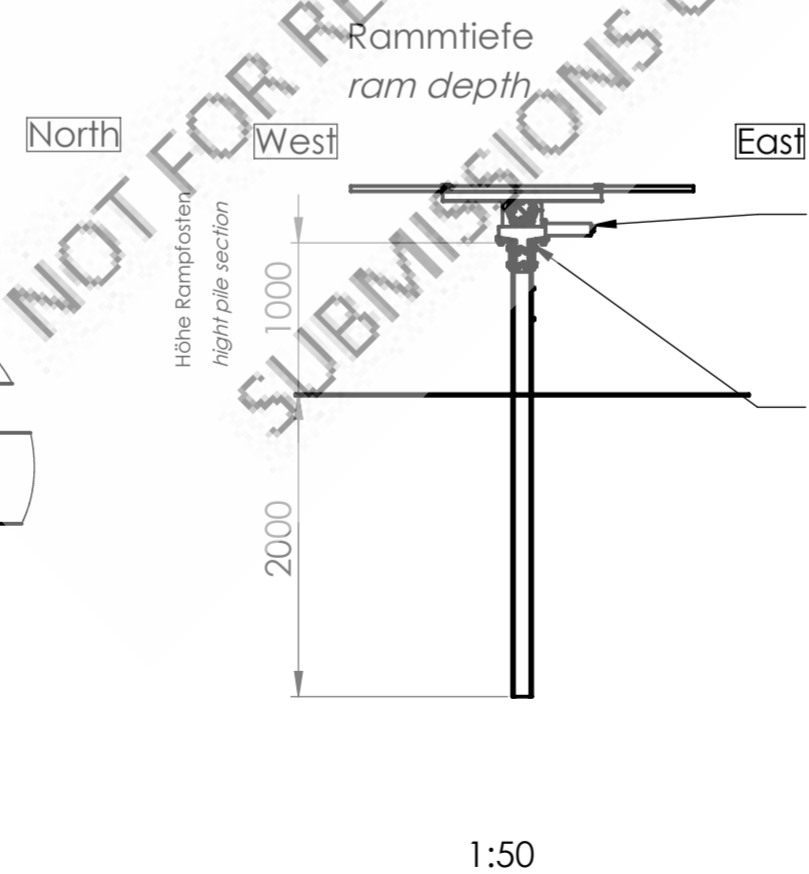
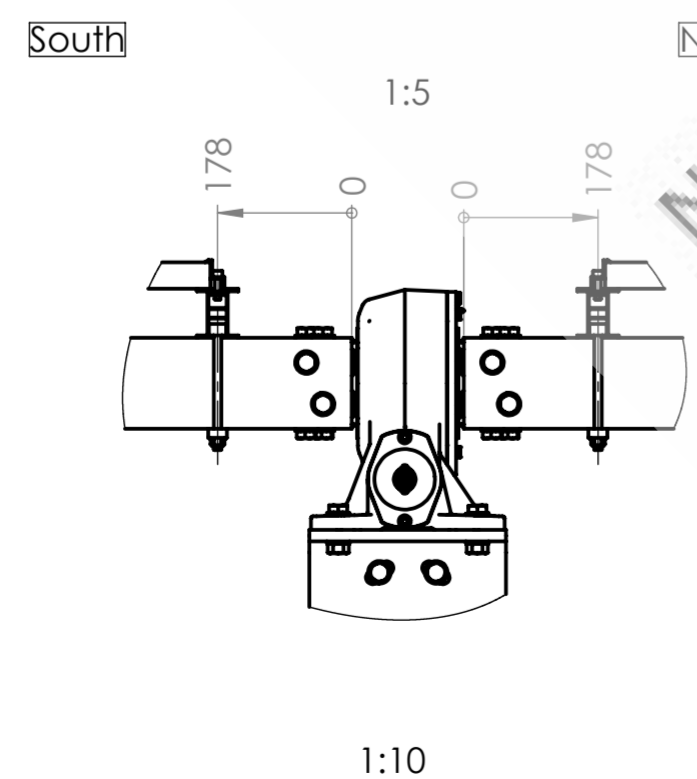
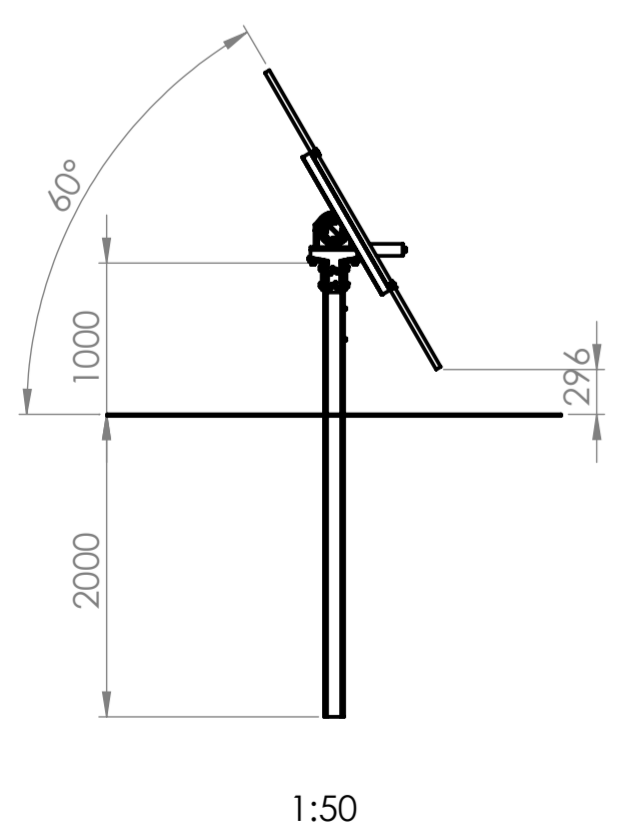

Achtung/ Attention:
Der Motor/ Getriebe muß im Osten montiert werden!
The motor/ gearbox have to be mounted in est direction!

Abstandstoleranz ± 20 der Rammpfosten muß am oberen Ende eingehalten werden
distance tolerance ± 20 have to be meet at the top of the pile sections

Preliminary design, not for construction!

- 86x xxxxxxx (aluminum module carrier L=xm)
- 86x 8200143 (clamping aluminum module carrier)
- 8x 3300118 (endclamp 35mm)
- 8x 6900007 (sliding nut M8)
- 8x 6100126 (bolt DIN912-M8x30-A2)
- 164x 6900016 (Middle plate)
- 164x 6100113 (bolt DIN912-M6x50-A2)
- 164x 6900006 (sliding nut M6)

		allowance	surface texture	scale 1:80	dimensions in millimeter	weight (g):
		general tolerances DIN ISO 2768-mK	DIN ISO 1302	material		
		date	name	part name		
		creator 02.11.2022	Omer Gulcan	S100-PF-SR-000		
		checked 02.11.2022	B. Yildiz	84x 2266x1134x35mm		
		DEGER energie GmbH&Co.KG Industriestraße 70, 72160 Horb +49 (0) 7451 539 140		part number	A2	
				S100-PF-SR	sheet 1 / 1	
rev.	description	date	name	origin	substitute	replaced by